



Air Conditioning & Heating

# GMSS92 / GCSS92

SINGLE-STAGE, MULTI-SPEED

GAS FURNACE

UP TO 92% AFUE

HEATING INPUT: 40,000–120,000 BTU/H



### Contents

Nomenclature.....	2
Product Specifications.....	3
Dimensions .....	5
Airflow Specifications.....	7
Wiring Diagram.....	10
Accessories .....	11

### Standard Features

- Heavy-duty aluminized-steel tubular heat exchanger
- Stainless-steel secondary heat exchanger
- Single-stage gas valve
- Durable Silicon Nitride igniter
- Multi-speed blower motor
- Quiet single-speed induced draft blower
- Self-diagnostic control board
- All models comply with California 40 ng/J Low NOx emissions standard
- AHRI Certified; ETL Listed

### Cabinet Features

- Designed for multi-position installation —  
GMSS92: upflow, horizontal left or right  
GCSS92: downflow, horizontal left or right
- Certified for direct vent (2-pipe) or on-direct vent (1-pipe)
- Easy-to-install top venting with optional side venting
- Convenient left or right connection for gas and electrical service
- Cabinet air leakage ( $Q_{Leak} \leq 2\%$ )
- Heavy-gauge steel cabinet with durable finish
- Foil-faced insulated heat exchanger cabinet
- Airtight solid bottom or side return with easy-cut tabs for effortless removal in bottom air-inlet applications



\* Complete warranty details available from your local dealer or at [www.goodmanmfg.com](http://www.goodmanmfg.com). To receive the Lifetime Heat Exchanger Limited Warranty (good for as long as you own your home), and 10-Year Parts Limited Warranty, online registration must be completed within 60 days of installation. Online registration is not required in California or Québec.

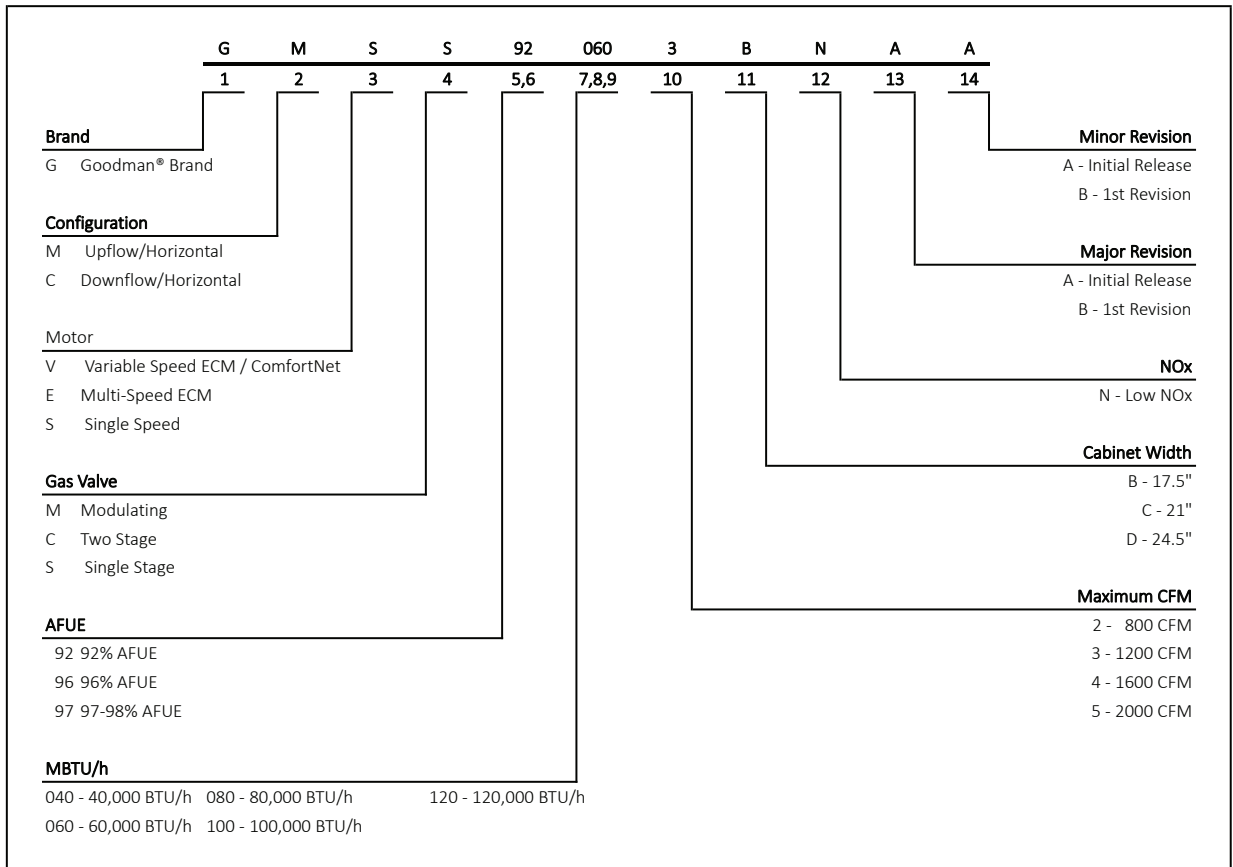

	GMSS92 0402BNA	GMSS92 0603BNA	GMSS92 0803BNA	GMSS92 0804CNA	GMSS92 0805CNA	GMSS92 1004CNA	GMSS92 1005CNA	GMSS92 1205DNA
<b>HEATING DATA</b>								
High Fire Input <sup>1</sup>	40,000	60,000	80,000	80,000	80,000	100,000	100,000	120,000
High Fire Output <sup>1</sup>	36,840	55,260	73,680	73,680	73,680	92,100	92,100	110,520
AFUE <sup>2</sup>	92	92	92	92	92	92	92	92
Temperature Rise Range (°F)	30 - 60	35 - 65	35 - 65	35 - 65	25 - 55	35 - 65	35 - 65	35 - 65
Vent Diameter <sup>3</sup>	2" - 3"	2" - 3"	2" - 3"	2" - 3"	2" - 3"	2" - 3"	2" - 3"	3"
No. OF BURNERS	2	3	4	4	4	5	5	6
<b>CIRCULATOR BLOWER</b>								
Available AC @ 0.5" ESP	1.5 - 3	1.5 - 3	1.5 - 3	3 - 5	3 - 5	3 - 5	3 - 5	3 - 5
Size (D x W)	10" x 8"	10" x 8"	10" x 8"	10" x 10"	11" x 10"	10" x 10"	11" x 10"	11" x 11"
Horsepower @ 1075 RPM	¼	¼	¼	½	¾	½	¾	¾
Speed	4	4	4	4	4	4	4	4
<b>ELECTRICAL DATA</b>								
Min. Circuit Ampacity <sup>4</sup>	9.6	9.6	9.6	11.7	13.7	11.7	13.7	13.7
Max. Overcurrent Device (amps) <sup>5</sup>	15	15	15	15	15	15	15	15
<b>SHIPPING WEIGHT (LBS)</b>								
	109	112	115	137	138	139	140	152

<sup>1</sup> Natural Gas BTU/h

<sup>2</sup> DOE AFUE based upon Isolated Combustion System (ICS)

<sup>3</sup> Installer must supply one or two PVC pipes: one for combustion air (optional) and one for the flue outlet (required). Vent pipe must be either 2" or 3" in diameter, depending upon furnace input, number of elbows, length of run and installation (1 or 2 pipes). The optional Combustion Air Pipe is dependent on installation/code requirements and must be 2" or 3" diameter PVC.

<sup>4</sup> Minimum Circuit Ampacity = (1.25 x Circulator Blower Amps) + ID Blower amps. Wire size should be determined in accordance with National Electrical Codes. Extensive wire runs will require larger wire sizes.

<sup>5</sup> Maximum Overcurrent Protection Device refers to maximum recommended fuse or circuit breaker size. May use fuses or HACR-type circuit breakers of the same size as noted.

#### NOTES

- All furnaces are manufactured for use on 115 VAC, 60 Hz, single-phase electrical supply.
- Gas Service Connection ½" FPT
- Important: Size fuses and wires properly and make electrical connections in accordance with the National Electrical Code and/or all existing local codes.
- For bottom return: Failure to unfold flanges may reduce airflow by up to 18%. This could result in performance and noise issues.
- For servicing or cleaning, a 24" front clearance is required. Unit connections (electrical, flue and drain) may necessitate greater clearances than the minimum clearances listed above. In all cases, accessibility clearance must take precedence over clearances from the enclosure where accessibility clearances are greater.

	GCSS92 0402BNA	GCSS92 0603BNA	GCSS92 0804CNA	GCSS92 1005CNA
<b>HEATING DATA</b>				
High Fire Input <sup>1</sup>	40,000	60,000	80,000	100,000
High Fire Output <sup>1</sup>	36,840	55,260	73,680	92,100
AFUE <sup>2</sup>	92	92	92	92
Temperature Rise Range (°F)	30 - 60	35 - 65	35 - 65	35 - 65
Vent Diameter <sup>3</sup>	2" - 3"	2" - 3"	2" - 3"	2" - 3"
No. OF BURNERS	2	3	4	5
<b>CIRCULATOR BLOWER</b>				
Available AC @ 0.5" ESP	1.5 - 3	1.5 - 3	2.5 - 4	2.5 - 4
Size (D x W)	10" x 8"	10" x 8"	10" x 10"	11" x 10"
Horsepower @ 1075 RPM	⅓	⅓	½	¾
Speed	4	4	4	4
<b>ELECTRICAL DATA</b>				
Min. Circuit Ampacity <sup>4</sup>	9.6	9.6	11.7	13.7
Max. Overcurrent Device (amps) <sup>5</sup>	15	15	15	15
<b>SHIPPING WEIGHT (LBS)</b>				
	109	112	137	140

<sup>1</sup> Natural Gas BTU/h

<sup>2</sup> DOE AFUE based upon Isolated Combustion System (ICS)

<sup>3</sup> Installer must supply one or two PVC pipes: one for combustion air (optional) and one for the flue outlet (required). Vent pipe must be either 2" or 3" in diameter, depending upon furnace input, number of elbows, length of run and installation (1 or 2 pipes). The optional Combustion Air Pipe is dependent on installation/code requirements and must be 2" or 3" diameter PVC.

<sup>4</sup> Minimum Circuit Ampacity = (1.25 x Circulator Blower Amps) + ID Blower amps. Wire size should be determined in accordance with National Electrical Codes. Extensive wire runs will require larger wire sizes.

<sup>5</sup> Maximum Overcurrent Protection Device refers to maximum recommended fuse or circuit breaker size. May use fuses or HACR-type circuit breakers of the same size as noted.

**NOTES**

- All furnaces are manufactured for use on 115 VAC, 60 Hz, single-phase electrical supply.
- Gas Service Connection ½" FPT
- Important: Size fuses and wires properly and make electrical connections in accordance with the National Electrical Code and/or all existing local codes.
- For bottom return: Failure to unfold flanges may reduce airflow by up to 18%. This could result in performance and noise issues.
- For servicing or cleaning, a 24" front clearance is required. Unit connections (electrical, flue and drain) may necessitate greater clearances than the minimum clearances listed above. In all cases, accessibility clearance must take precedence over clearances from the enclosure where accessibility clearances are greater.

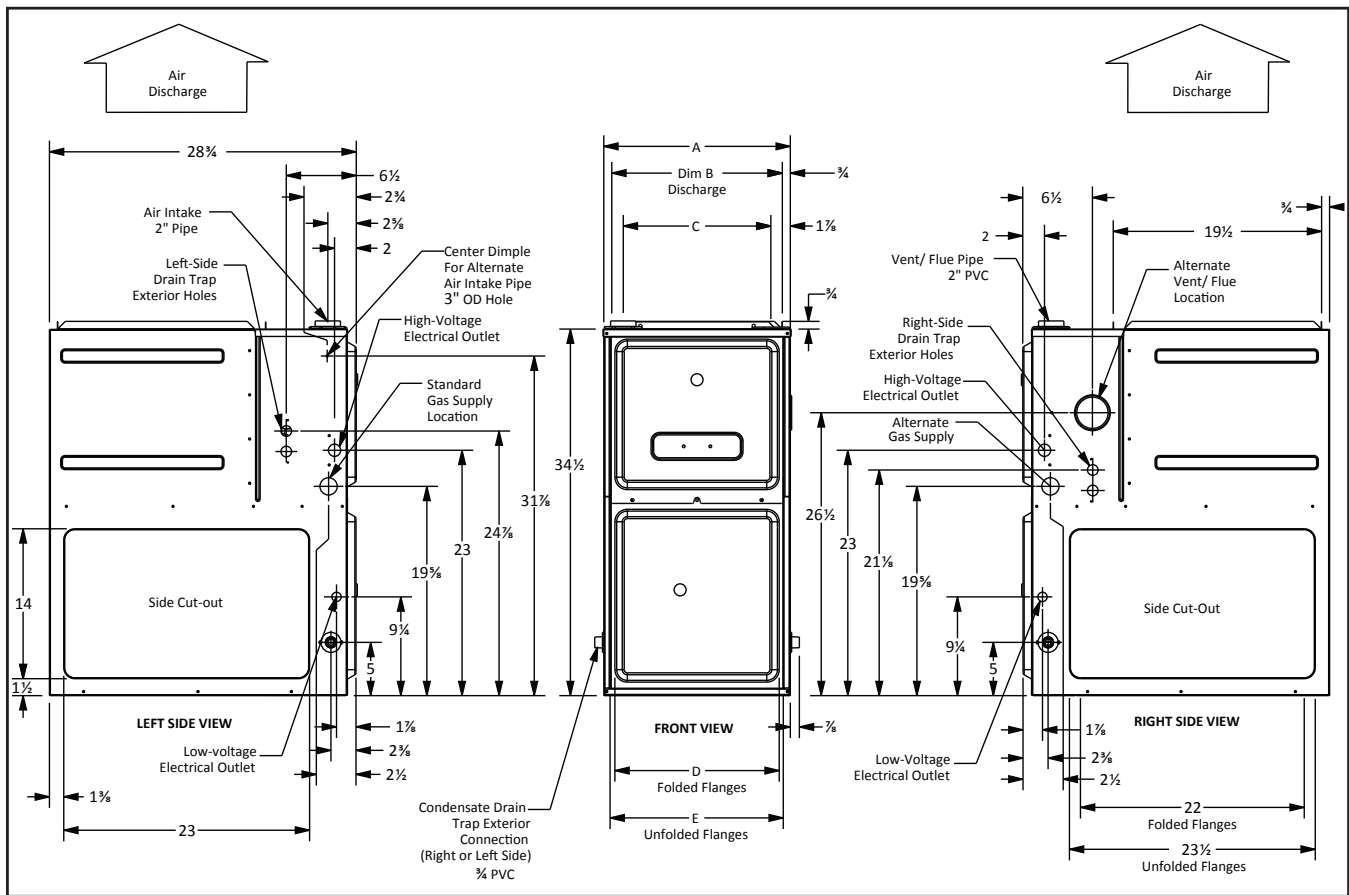

MODEL	A	B	C	D	E
GMSS920402BNA	17½"	16"	13⅞"	12⅞"	13⅞"
GMSS920603BNA	17½"	16"	13⅞"	12⅞"	13⅞"
GMSS920803BNA	17½"	16"	13⅞"	12⅞"	13⅞"
GMSS920804CNA	21"	19½"	17⅞"	16"	17½"
GMSS920805CNA	21"	19½"	17⅞"	16"	17½"
GMSS921004CNA	21"	19½"	17⅞"	16"	17½"
GMSS921005CNA	21"	19½"	17⅞"	16"	17½"
GMSS921205DNA	24½"	23"	20⅞"	19⅞"	20⅞"

**MINIMUM CLEARANCES TO COMBUSTIBLE MATERIALS**

POSITION	SIDES	REAR	FRONT	BOTTOM	FLUE	TOP
Upflow	0"	0"	3"	C	0"	1"
Horizontal	6"	0"	3"	C	0"	6"

C = If placed on combustible floor, the floor MUST be wood ONLY.

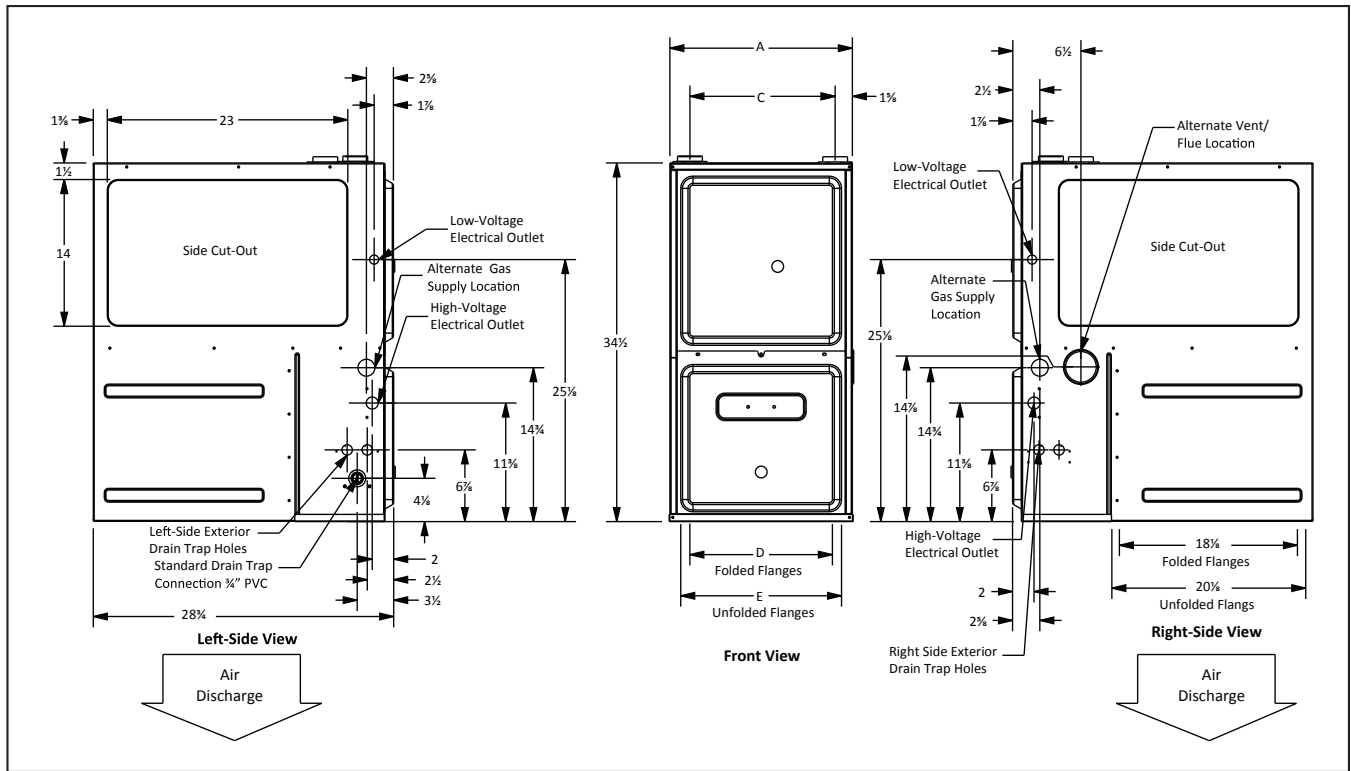

MODEL	A	B	C	D	E
GCSS920402BNA	17 1/2"	14 5/8"	14"	14 1/2"	16"
GCSS920603BNA	17 1/2"	14 5/8"	14"	14 1/2"	16"
GCSS920804CNA	21"	18 3/8"	17 1/2"	18"	19 1/2"
GCSS921005CNA	21"	18 3/8"	17 1/2"	18"	19 1/2"

**MINIMUM CLEARANCES TO COMBUSTIBLE MATERIALS**

POSITION	SIDES	REAR	FRONT	BOTTOM	FLUE	TOP
Downflow	0"	0"	3"	NC	0"	1"
Horizontal	6"	0"	3"	C	0"	6"

C = If placed on combustible floor, the floor MUST be wood ONLY.

NC = For installation on non-combustible floors only. A combustible floor sub-base must be used for installations on combustible flooring.

(CFM & TEMPERATURE RISE VS. EXTERNAL STATIC PRESSURE)

MODEL	MOTOR SPEED	TONS AC <sup>1</sup>	EXTERNAL STATIC PRESSURE, (INCHES WATER COLUMN)												
			0.1		0.2		0.3		0.4		0.5		0.6	0.7	0.8
			CFM	RISE	CFM	RISE	CFM	RISE	CFM	RISE	CFM	RISE	CFM	CFM	CFM
GMSS92 0402BNA	High	3	1,498	N/A	1,446	N/A	1,368	N/A	1,302	N/A	1,227	N/A	1,145	1,059	954
	Med	2.5	1,223	N/A	1,182	N/A	1,153	30	1,099	31	1,051	32	982	901	813
	Med-Lo	2	983	35	971	35	945	36	919	37	878	39	813	746	659
	Low	1.5	816	42	794	43	758	45	734	46	678	50	637	597	523
GMSS92 0603BNA	High	3	1,494	N/A	1,428	36	1,362	38	1,294	39	1,231	42	1,162	1,076	972
	Med	2.5	1,203	42	1,178	43	1,147	45	1,101	46	1,045	49	986	927	831
	Med-Lo	2	977	52	965	53	939	54	904	57	866	59	801	763	639
	Low	1.5	801	64	786	65	751	N/A	714	N/A	714	N/A	680	635	596
GMSS92 0803BNA	High	3	1,459	47	1,397	49	1,339	51	1,270	54	1,202	57	1,107	1,049	952
	Med	2.5	1,191	57	1,166	58	1,137	60	1,086	63	1,033	N/A	973	889	797
	Med-Lo	2	985	N/A	967	N/A	932	N/A	900	N/A	859	N/A	805	731	620
	Low	1.5	808	N/A	785	N/A	758	N/A	726	N/A	679	N/A	629	590	513
GMSS92 0804CNA	High	5	2,115	N/A	2,050	N/A	1,973	35	1,915	36	1,810	38	1,695	1,587	1,467
	Med	4	1,802	38	1,739	39	1,725	40	1,665	41	1,612	42	1,532	1,443	1,320
	Med-Lo	3.5	1,517	45	1,509	45	1,496	46	1,475	46	1,441	47	1,388	1,304	1,205
	Low	3	1,213	56	1,225	56	1,216	56	1,194	57	1,179	58	1,135	1,084	1,005
GMSS92 0805CNA	High	5	2,284	30	2,231	31	2,170	31	2,103	32	2,037	33	1,945	1,836	1,750
	Med	4	1,865	37	1,869	36	1,775	38	1,732	39	1,684	40	1,619	1,548	1,480
	Med-Lo	3.5	1,594	43	1,571	43	1,530	45	1,492	46	1,454	47	1,414	1,355	1,293
	Low	3	1,411	48	1,366	50	1,325	51	1,296	53	1,251	54	1,200	1,147	1,096
GMSS92 1004CNA	High	5	2,082	41	1,997	43	1,943	44	1,847	46	1,749	49	1,669	1,560	1,443
	Med	4	1,823	47	1,782	48	1,711	50	1,659	51	1,574	54	1,513	1,402	1,305
	Med-Lo	3.5	1,565	54	1,545	55	1,529	56	1,487	57	1,441	59	1,365	1,287	1,196
	Low	3	1,261	N/A	1,237	N/A	1,242	N/A	1,216	N/A	1,179	N/A	1,145	1,098	1,034
GMSS92 1005CNA	High	5	2,137	40	2,073	41	2,031	42	1,949	44	1,879	45	1,811	1,734	1,625
	Med	4	1,793	48	1,754	49	1,704	50	1,648	52	1,590	54	1,534	1,451	1,371
	Med-Lo	3.5	1,558	55	1,518	56	1,477	58	1,425	60	1,376	62	1,316	1,242	1,170
	Low	3	1,370	62	1,325	64	1,288	N/A	1,237	N/A	1,191	N/A	1,134	1,086	1,024
GMSS92 1205DNA	High	5	2,256	45	2,192	47	2,133	48	2,054	50	1,986	51	1,907	1,834	1,718
	Med	4	1,805	57	1,762	58	1,722	59	1,677	61	1,618	63	1,563	1,507	1,441
	Med-Lo	3.5	1,565	65	1,513	N/A	1,480	N/A	1,415	N/A	1,392	N/A	1,346	1,269	1,198
	Low	3	1,368	N/A	1,326	N/A	1,278	N/A	1,238	N/A	1,208	N/A	1,165	1,093	1,052

<sup>1</sup> at 0.5" ESP

**NOTES**

- CFM in chart is without filter(s). Filters do not ship with this furnace, but must be provided by the installer. If the furnace requires two return filters, this chart assumes both filters are installed.
- All furnaces ship as high-speed cooling and medium-speed heating. Installer must adjust blower cooling & heating speed as needed.
- For most jobs, about 400 CFM per ton when cooling is desirable.
- INSTALLATION IS TO BE ADJUSTED TO OBTAIN TEMPERATURE RISE WITHIN THE RANGE SPECIFIED ON THE RATING PLATE.
- This chart is for information only. For satisfactory operation, external static pressure should not exceed value shown on the rating plate. The shaded area indicates ranges in excess of maximum static pressure allowed when heating.
- The above chart is for U.S. furnaces installed at 0-2000 feet. At higher altitudes, a properly derated unit will have approximately the same temperature rise at a particular CFM, while ESP at the CFM will be lower.

**MINIMUM FILTER SIZES**

	GMSS92 0402BNA	GMSS92 0603BNA	GMSS92 0803BNA	GMSS92 0804CNA	GMSS92 0805CNA	GMSS92 1004CNA	GMSS92 1005CNA	GMSS92 1205DNA
Filter Size (in <sup>2</sup> ) (Qty)	(1) 16 x 25 (side or bottom)				(1) 20 x 25 (bottom) or (2) 16 x 25 (side)	(1) 16 x 25 (side or bottom)	(1) 20 x 25 (bottom) or (2) 16 x 25 (side)	

Note: Other size filters of equal or greater dimensions may be used. Filters may also be centrally located.

(CFM & TEMPERATURE RISE VS. EXTERNAL STATIC PRESSURE)

MODEL	MOTOR SPEED	TONS AC <sup>1</sup>	EXTERNAL STATIC PRESSURE, (INCHES WATER COLUMN)												
			0.1		0.2		0.3		0.4		0.5		0.6	0.7	0.8
			CFM	RISE	CFM	RISE	CFM	RISE	CFM	RISE	CFM	RISE	CFM	CFM	CFM
GCSS92 0402BNA	High	3	1,400	N/A	1,331	N/A	1,263	N/A	1,189	N/A	1,106	31	1,020	941	843
	Med	2.5	1,204	N/A	1,176	N/A	1,121	30	1,072	32	1,002	34	927	853	740
	Med-Lo	2	1,020	33	998	34	968	35	923	37	880	39	820	739	652
	Low	1.5	841	41	827	41	797	43	766	44	727	47	680	634	556
GCSS92 0603BNA	High	3	1,668	31	1,335	38	1,288	40	1,207	42	1,133	45	1,061	955	845
	Med	2.5	1,224	42	1,182	43	1,139	45	1,088	47	1,015	50	948	859	759
	Med-Lo	2	1,030	50	1,005	51	988	52	942	54	893	57	830	751	666
	Low	1.5	859	60	830	62	815	63	789	65	751	N/A	693	629	556
GCSS92 0804BNA	High	4	1,770	39	1,645	41	1,610	42	1,528	45	1,437	47	1,340	1,251	1,141
	Med	3.5	1,690	40	1,615	42	1,531	45	1,470	46	1,393	49	1,308	1,196	1,099
	Med-Lo	3	1,612	42	1,540	44	1,472	46	1,398	49	1,306	52	1,223	1,132	1,010
	Low	2.5	1,396	49	1,339	51	1,304	52	1,250	55	1,170	58	1,092	1,010	906
GCSS92 1005CNA	High	4	1,793	48	1,699	50	1,610	53	1,533	56	1,461	58	1,363	1,247	1,146
	Med	3.5	1,693	50	1,622	53	1,552	55	1,467	58	1,390	61	1,320	1,205	1,083
	Med-Lo	3	1,632	52	1,546	55	1,493	57	1,415	60	1,332	64	1,257	1,148	1,054
	Low	2.5	1,429	60	1,380	62	1,334	64	1,258	N/A	1,199	N/A	1,136	1,041	942

<sup>1</sup> at 0.5" ESP

**NOTES**

- CFM in chart is without filter(s). Filters do not ship with this furnace, but must be provided by the installer. If the furnace requires two return filters, this chart assumes both filters are installed.
- All furnaces ship as high-speed cooling and medium-speed heating. Installer must adjust blower cooling & heating speed as needed.
- For most jobs, about 400 CFM per ton when cooling is desirable.
- INSTALLATION IS TO BE ADJUSTED TO OBTAIN TEMPERATURE RISE WITHIN THE RANGE SPECIFIED ON THE RATING PLATE.
- This chart is for information only. For satisfactory operation, external static pressure should not exceed value shown on the rating plate. The shaded area indicates ranges in excess of maximum static pressure allowed when heating.
- The above chart is for U.S. furnaces installed at 0-2000 feet. At higher altitudes, a properly derated unit will have approximately the same temperature rise at a particular CFM, while ESP at the CFM will be lower.

**MINIMUM FILTER SIZES**

	GCSS92 0402BNA	GCSS92 0603BNA	GCSS92 0804CNA	GCSS92 1005CNA
Filter Size (in <sup>2</sup> ) (Qty)	(2) 10 x 20 or (1) 16 x 25 (top return)			(1) 14 x 20 (bottom) or (1) 20 x 25 (top return)

Note: Other size filters of equal or greater dimensions may be used. Filters may also be centrally located.



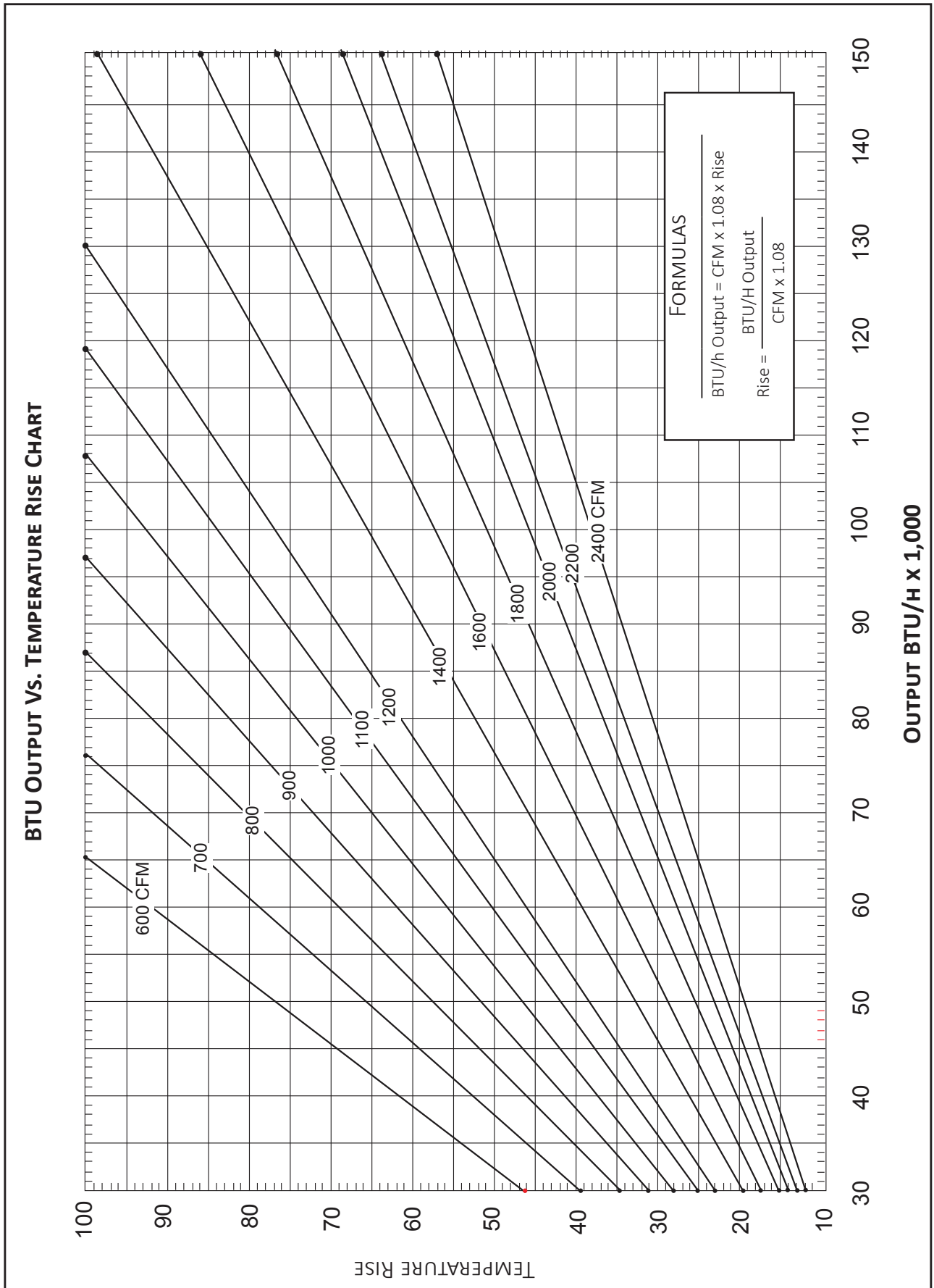

# WIRING DIAGRAM

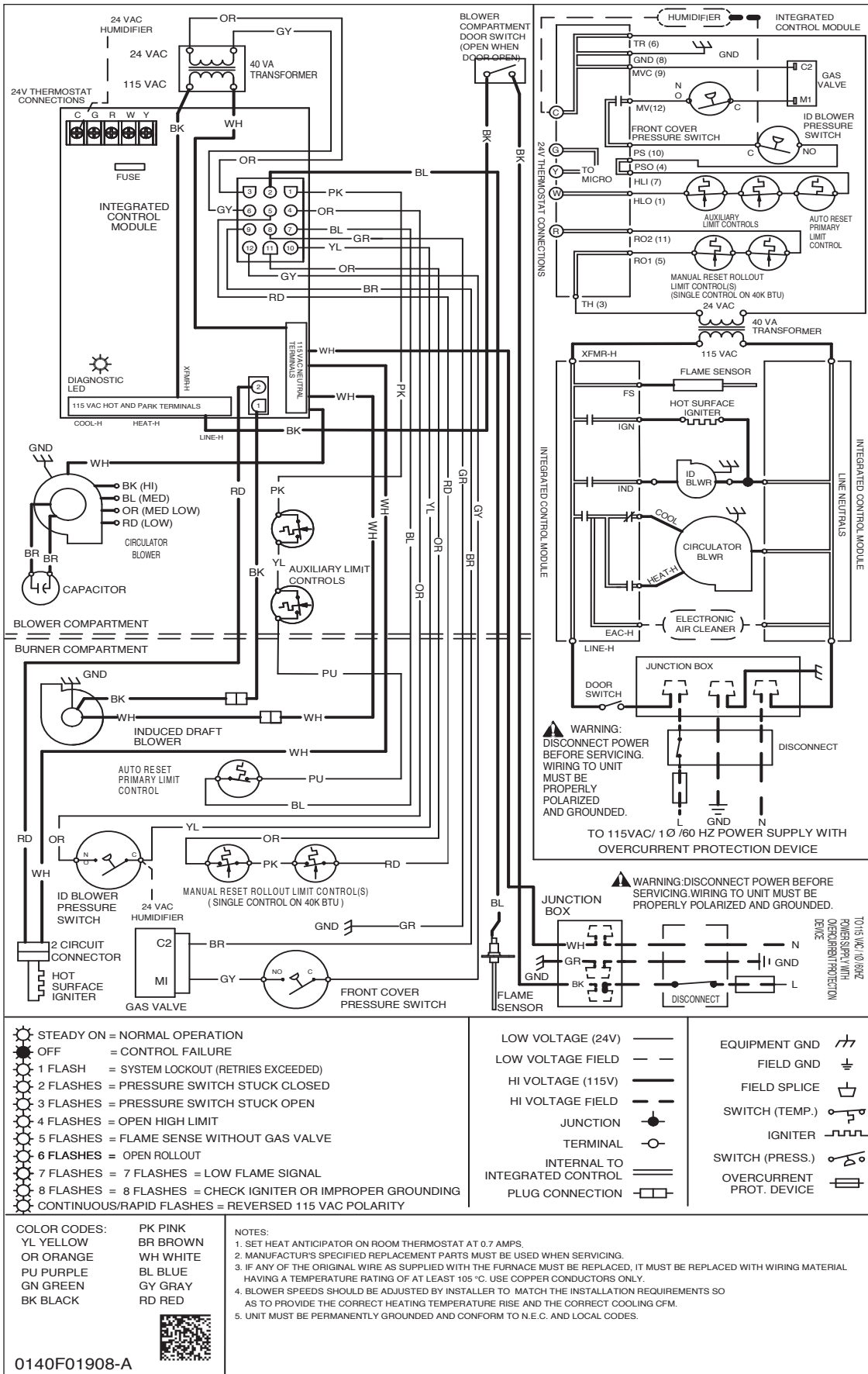

**High Voltage:** Disconnect all power before servicing or installing this unit. Multiple power sources may be present. Failure to do so may cause property damage, personal injury, or death.

**WARNING**

Wiring is subject to change. Always refer to the wiring diagram on the unit for the most up-to-date wiring.

- STEADY ON = NORMAL OPERATION
- OFF = CONTROL FAILURE
- 1 FLASH = SYSTEM LOCKOUT (RETRIES EXCEEDED)
- 2 FLASHES = PRESSURE SWITCH STUCK CLOSED
- 3 FLASHES = PRESSURE SWITCH STUCK OPEN
- 4 FLASHES = OPEN HIGH LIMIT
- 5 FLASHES = FLAME SENSE WITHOUT GAS VALVE
- 6 FLASHES = OPEN ROLLOUT
- 7 FLASHES = 7 FLASHES = LOW FLAME SIGNAL
- 8 FLASHES = 8 FLASHES = CHECK IGNITER OR IMPROPER GROUNDING
- CONTINUOUS/RAPID FLASHES = REVERSED 115 VAC POLARITY

- LOW VOLTAGE (24V)
- — LOW VOLTAGE FIELD
- — HI VOLTAGE (115V)
- — HI VOLTAGE FIELD
- JUNCTION
- TERMINAL
- INTERNAL TO INTEGRATED CONTROL
- PLUG CONNECTION

- EQUIPMENT GND
- FIELD GND
- FIELD SPLICE
- SWITCH (TEMP.)
- IGNITER
- SWITCH (PRESS.)
- OVERCURRENT PROT. DEVICE

**COLOR CODES:**

YL YELLOW  
OR ORANGE  
PU PURPLE  
GN GREEN  
BK BLACK

PK PINK  
BR BROWN  
WH WHITE  
BL BLUE  
GY GRAY  
RD RED

- NOTES:**
1. SET HEAT ANTICIPATOR ON ROOM THERMOSTAT AT 0.7 AMPS.
  2. MANUFACTURER'S SPECIFIED REPLACEMENT PARTS MUST BE USED WHEN SERVICING.
  3. IF ANY OF THE ORIGINAL WIRE AS SUPPLIED WITH THE FURNACE MUST BE REPLACED, IT MUST BE REPLACED WITH WIRING MATERIAL HAVING A TEMPERATURE RATING OF AT LEAST 105 °C. USE COPPER CONDUCTORS ONLY.
  4. BLOWER SPEEDS SHOULD BE ADJUSTED BY INSTALLER TO MATCH THE INSTALLATION REQUIREMENTS SO AS TO PROVIDE THE CORRECT HEATING TEMPERATURE RISE AND THE CORRECT COOLING CFM.
  5. UNIT MUST BE PERMANENTLY GROUNDED AND CONFORM TO N.E.C. AND LOCAL CODES.

0140F01908-A

MODEL	DESCRIPTION	GMSS92 0402BNA	GMSS92 0603BNA	GMSS92 0803BNA	GMSS92 0804CNA	GMSS92 0805CNA	GMSS92 1004CNA	GMSS92 1005CNA	GMSS92 1205DNA
CVENT-2	Concentric Vent Kit (2")	√	√	√	√	√	√	√	---
CVENT-3	Concentric Vent Kit (3")	√	√	√	√	√	√	√	√
CFSB17	Downflow Sub-Base 17.5"	---	---	---	---	---	---	---	---
CFSB21	Downflow Sub-Base 21"	---	---	---	---	---	---	---	---
CFSB24	Downflow Sub-Base 24"	---	---	---	---	---	---	---	---
RF000142	Drain Kit -Horizontal Left Vertical Flue	√	√	√	√	√	√	√	√
EFR02	External Filter Rack with 16"x25" Permanent Filter	√	√	√	√	---	√	---	---
O170K00000S	Flush Mount Vent Kit - 3" or 2"	√	√	√	√	√	√	√	√
O170K00001S	Flush Mount Vent Kit - 2"	√	√	√	√	√	√	√	---
AFE18-60A	Fossil Fuel (Dual Fuel) Kit	√	√	√	√	√	√	√	√
HASFK	High-Altitude Natural Gas Kit	HASFK-4	HASFK-4	HASFK-4	HASFK-4	HASFK-4	HASFK-4	HASFK-4	HASFK-4
HASFK	High-Altitude LP Gas Kit	HASFK-4	HASFK-4	HASFK-5	HASFK-4	HASFK-4	HASFK-4	HASFK-5	HASFK-4
LPLP03	Low LP Gas Pressure Switch	√	√	√	√	√	√	√	√
LPM-07	LP Conversion Kits	√	√	√	√	√	√	√	√
FTK04	Twinning Kit	√	√	√	√	√	√	√	√

MODEL	DESCRIPTION	GCSS92 0402BNA	GCSS92 0603BNA	GCSS92 0804CNA	GCSS92 1005CNA
CVENT-2	Concentric Vent Kit (2")	√	√	√	√
CVENT-3	Concentric Vent Kit (3")	√	√	√	√
CFSB17	Downflow Sub-Base 17.5"	√	√	---	---
CFSB21	Downflow Sub-Base 21"	---	---	√	√
CFSB24	Downflow Sub-Base 24"	---	---	---	---
RF000142	Drain Kit -Horizontal Left Vertical Flue	---	---	---	---
EFR02	External Filter Rack with 16"x25" Permanent Filter	√	√	√	---
O170K00000S	Flush Mount Vent Kit - 3" or 2"	√	√	√	√
O170K00001S	Flush Mount Vent Kit - 2"	√	√	√	√
AFE18-60A	Fossil Fuel (Dual Fuel) Kit	√	√	√	√
HASFK	High-Altitude Natural Gas Kit	HASFK-4	HASFK-4	HASFK-4	HASFK-4
HASFK	High-Altitude LP Gas Kit	HASFK-4	HASFK-4	HASFK-5	HASFK-4
LPLP03	Low LP Gas Pressure Switch	√	√	√	√
LPM-07	LP Conversion Kits	√	√	√	√
FTK04	Twinning Kit	√	√	√	√

